

NP12-180(12V180AH)

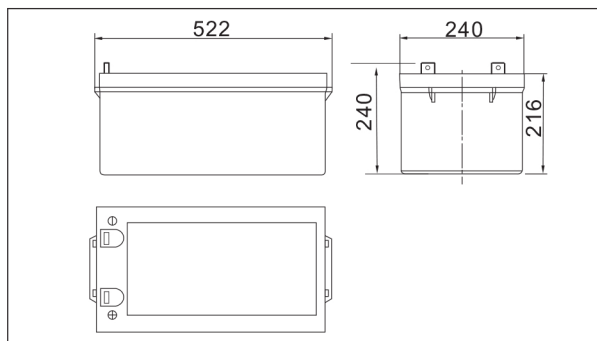

● **Outer dimensions (mm)**



● **Specifications**

Nominal Voltage		12V
Rated capacity (10 hour rate)		180 Ah
Dimensions	Total Height	240mm (9.45inches)
	Height	216mm (8.50 inches)
	Length	522mm (20.6 inches)
	Width	240mm (9.45 inches)
Weight Approx		56.5Kg (124lbs)

● **Terminal Type (mm)**

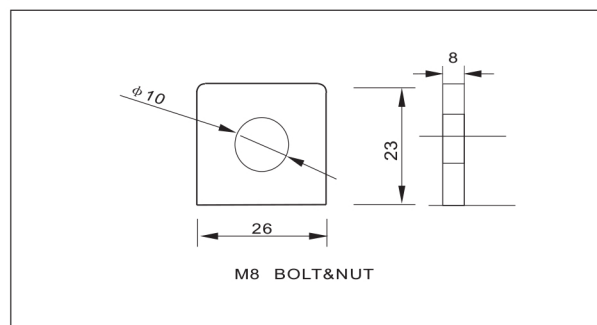

● **Characteristics**

Capacity 25°C(77°F)	10 hour rate(18.0A)	180 AH
	5 hour rate(28.8A)	144 AH
	1 hour rate(108A)	108 AH
	1.5 hour discharge to 10.5V	72 A
Internal Resistance	Full charged Battery at 25°C(77°F)	3.3mΩ
Capacity affected by Temperature (10hour rate)	40°C(104°F)	102%
	25°C(77°F)	100%
	0°C(32°F)	85%
	-15°C(5°F)	65%
Self-Discharge at 25°C(77°F)	Capacity after 3 month storage	91%
	Capacity after 6 month storage	82%
	Capacity after 12 month storage	64%
Terminal		T9
Charge (constant Voltage)	Cycle	Initial Charging Current less than 45A Voltage 14.40-14.80V(Time14~16h)
	Float	Voltage 13.50-13.80V

● **Discharge Curves 25°C(77°F)**

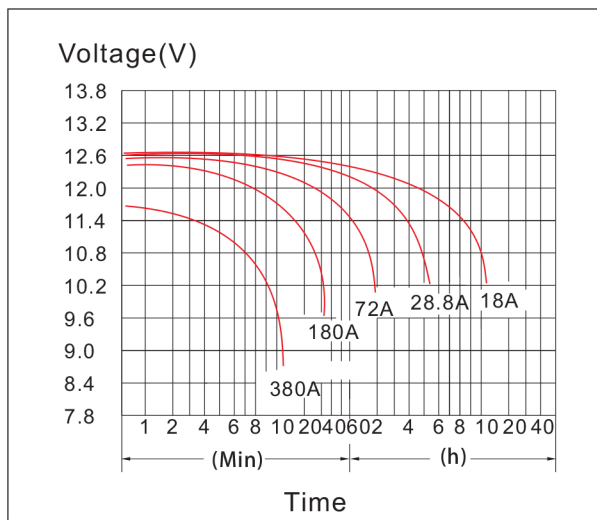

Time	5min	10min	15min	30min	1h	2h	3h	4h	5h	8h	10h	20h
9.60V	A	577	380	306	205.2	108.0	63.0	46.3	36.0	29.7	21.06	10.21
	W	6054	4056	3283	2206	1166	692	515	405	338	241	118.7
10.20V	A	558	343	288	196.2	101.5	60.1	45.0	35.1	29.2	20.52	9.90
	W	5963	3827	3227	2203	1148	693	521	408	340	240	116.1
10.50V	A	540	307	252	183.6	98.3	58.7	43.9	34.6	28.8	20.34	9.90
	W	5899	3487	2878	2113	1138	681	512	404	338	239	117.0
10.80V	A	521	289	234	169.2	95.0	57.2	42.8	34.0	28.1	19.80	9.72
	W	5841	3332	2700	1960	1106	670	505	402	332	235	115.8
11.10V	A	503	271	216	151.2	91.8	55.8	41.4	33.1	27.4	19.26	9.18
	W	5705	3135	2518	1769	1080	660	492	394	327	231	111.3