

NP12-33(12V33AH)

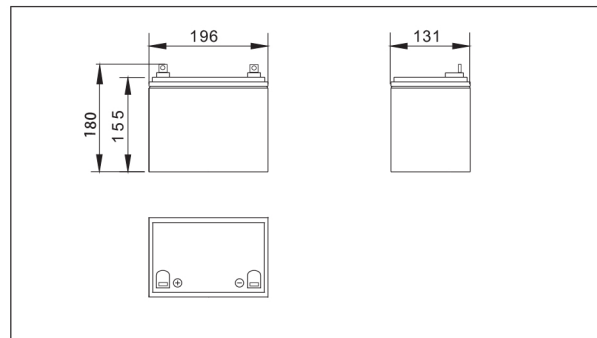

Outer dimensions (mm)



Specifications

Nominal Voltage		12V
Rated capacity (10 hour rate)		33 Ah
Dimensions	Total Height	180 mm (7.09 inches)
	Height	155 mm (6.10 inches)
	Length	196 mm (7.70 inches)
	Width	131mm (5.16 inches)
Weight Approx		10.0Kg (22.0lbs)

Terminal Type (mm)

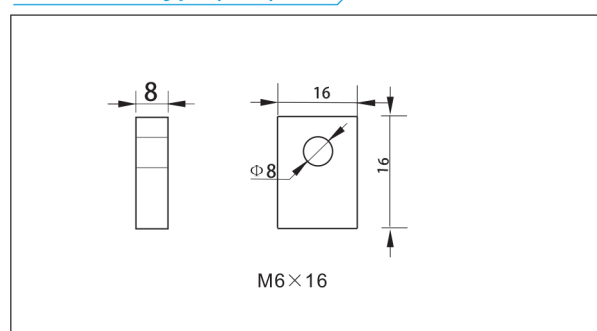

Characteristics

Capacity 25°C(77°F)	10 hour rate(3.3 A)	33.0 AH
	5 hour rate(5.28A)	26.4AH
	1 hour rate(19.8 A)	19.8 AH
	1.5 hour discharge to 10.5V	13.2A
Internal Resistance	Full charged Battery at 25°C(77°F)	9.5m Ω
Capacity affected by Temperature (10hour rate)	40°C(104°F)	102%
	25°C(77°F)	100%
	0°C(32°F)	85%
	-15°C(5°F)	65%
Self-Discharge at 25°C(77°F)	Capacity after 3 month storage	91%
	Capacity after 6 month storage	82%
	Capacity after 12 month storage	64%
Terminal		T16
Charge (constant Voltage)	Cycle	Initial Charging Current less than 13.2 A Voltage 14.40-14.80V Time 14~16h
	Float	Voltage 13.50-13.80V

Discharge Curves 25°C(77°F)

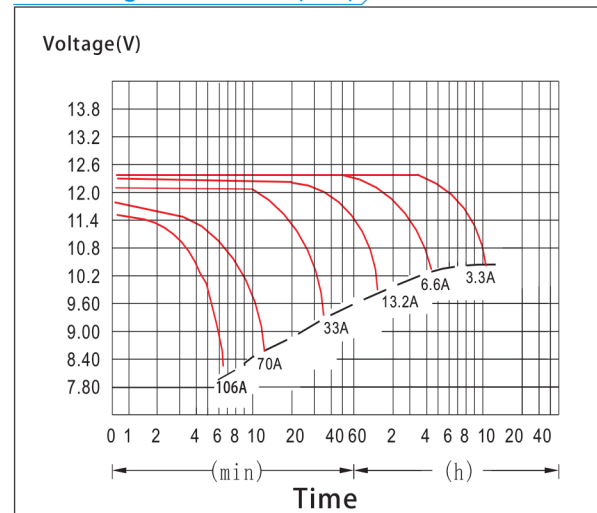

Constant Current(Amp) and Constant Power(Watt) Discharge Table at 25°C(77°F)

Time		5min	10min	15min	30min	1h	2h	3h	4h	5h	8h	10h	20h
9.60V	A	106	69.6	56.1	37.6	19.8	11.6	8.48	6.60	5.45	3.86	3.47	1.87
	W	1091	744	602	404	214	127	94.4	74.3	61.9	44.2	40.0	21.8
10.20V	A	103	62.8	52.9	36.0	18.6	11.0	8.25	6.44	5.35	3.76	3.40	1.82
	W	1087	702	592	404	211	127	95.5	74.8	62.3	44.0	39.9	21.3
10.50V	A	99.0	56.2	46.2	33.7	18.0	10.8	8.05	6.34	5.28	3.73	3.33	1.82
	W	1081	639	528	387	209	125	93.8	74.1	61.9	43.9	39.4	21.5
10.80V	A	95.4	53.0	43.0	31.0	17.4	10.5	7.85	6.24	5.15	3.63	3.30	1.78
	W	1071	611	495	359	203	123	92.6	73.6	60.8	43.0	39.2	21.2
11.10V	A	92.2	49.6	39.7	27.7	16.8	10.2	7.59	6.07	5.02	3.53	3.14	1.68
	W	1046	575	462	324	198	121	90.2	72.3	59.9	42.3	37.8	20.4