

**NPG12-50(12V50AH)**

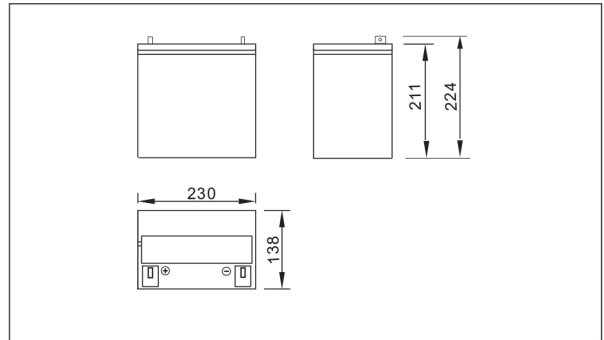

● **Outer dimensions (mm)**



● **Specifications**

Nominal Voltage		12V
Rated capacity (20 hour rate)		50 Ah
Dimensions	Total Height	229 mm (9.01 inches)
	Height	211 mm (8.30 inches)
	Length	230 mm (9.06 inches)
	Width	138 mm (5.43 inches)
Weight Approx		16.2Kg (35.6 lbs)

● **Terminal Type (mm)**

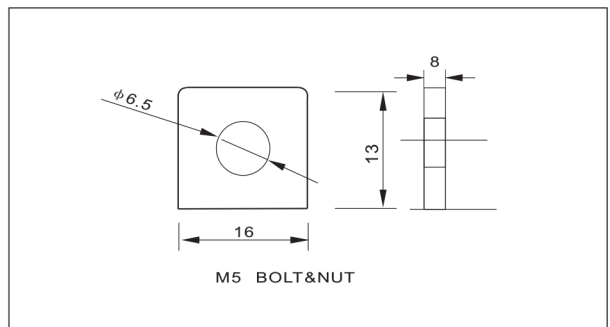

● **Characteristics**

Capacity 25°C(77°F)	20 hour rate(2.50 A)	50.0AH
	5 hour rate(8.5 A)	42.5AH
	1 hour rate(30A)	30.0AH
	1.5 hour discharge to 10.5V	20 A
Internal Resistance	Full charged Battery at 25°C(77°F)	6 mΩ
Capacity affected by Temperature (10hour rate)	40°C(104°F)	102%
	25°C(77°F)	100%
	0°C(32°F)	85%
	-15°C(5°F)	65%
Self-Discharge at 25°C(77°F)	Capacity after 3 month storage	91%
	Capacity after 6 month storage	82%
	Capacity after 12 month storage	64%
Terminal		T9, T16
Charge (constant Voltage)	Cycle	Initial Charging Current less than 20 A Voltage 14.40-14.80V Time 14~16h
	Float	Voltage 13.50-13.80V

● **Discharge Curves 25°C(77°F)**

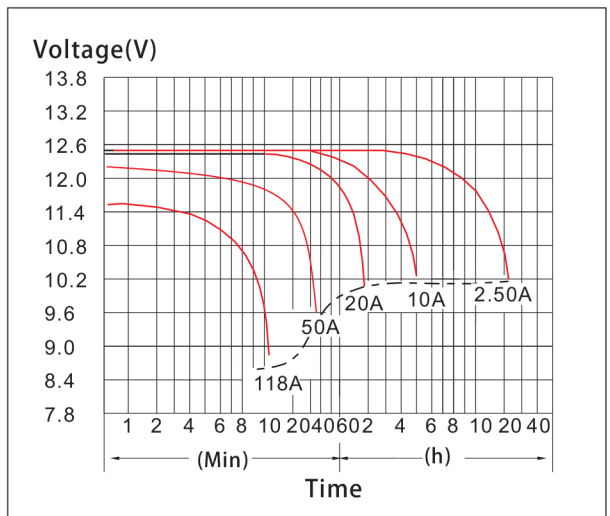

Time	5min	10min	15min	30min	1h	2h	3h	4h	5h	8h	10h	20h	
9.60V	A	180	118	87.5	57.5	30.0	17.5	12.9	10.3	8.77	5.79	4.73	2.58
	W	1868	1267	938	618	324	192	143	116	100	66.4	54.6	30.0
10.20V	A	165	113	80.4	54.6	28.2	16.8	12.5	10.0	8.60	5.69	4.65	2.52
	W	1772	1262	900	613	319	194	145	116	100	66.5	54.6	29.6
10.50V	A	150	106	75.0	52.9	27.3	16.5	12.3	9.5	8.50	5.63	4.60	2.50
	W	1649	1200	856	609	316	191	143	111	100	66.2	54.4	29.6
10.80V	A	144	101	70.0	51.5	26.3	16.0	12.1	9.3	8.13	5.48	4.48	2.44
	W	1620	1163	806	596	307	188	142	110	96	64.9	53.2	29.0
11.10V	A	134	95	65.0	50.0	25.4	15.6	11.5	9.2	7.77	5.33	4.38	2.38
	W	1514	1100	757	585	299	185	136	109	93	63.9	52.8	28.8